

Double arm ATC
30 tool capacity
3.5 s tool change time

Hardened and ground guide-ways are used in all axes. Worktable, cross slide and headstock are supported on pre-loaded roller packs. More efficient feed drives, ball screw with higher pitch, new slideway covers. Rapid traverse 30 m/min. Acceleration 5 m/s².

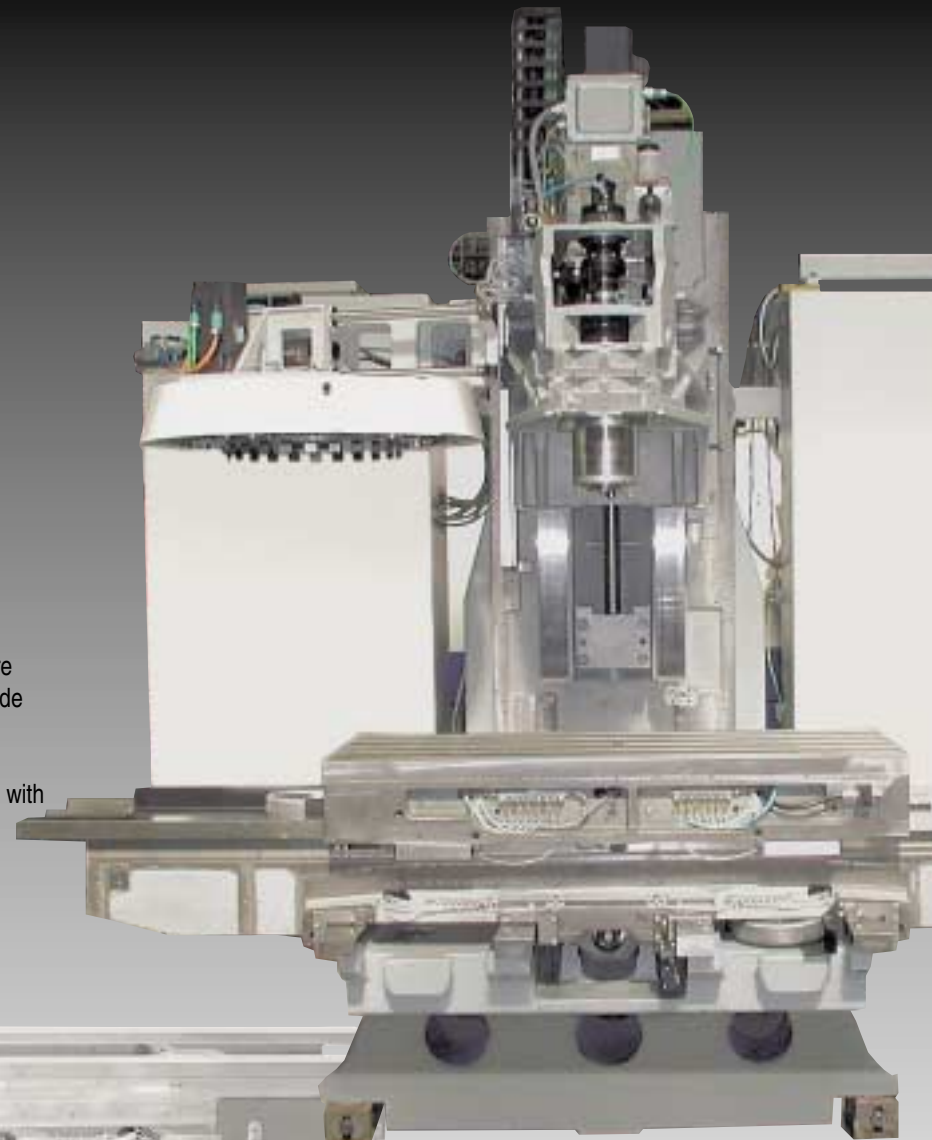

Tajmac-ZPS machining centres present top quality machines accepted by the most demanding world markets. Their success is based on their versatility, high performance, longlife precision and high reliability. Continuous innovation process of the machines is grounded in good understanding of customer needs and in implementation of the topmost technological know-how in metal cutting.



Top class technology combined with traditional ones. Hand scraped contact surfaces of the base and the column.